

Recirculation Pump AXD-I

Axial propeller pump designed to pump large amounts of liquids with low back pressure. The pump is often used at sewage treatment plants for recirculating sludge, but it can also be used in, for example, drainage and for recirculation at fish farming facilities.

APPLICATION EXAMPLES

- Recirculation in activated sludge processes
- Aqua culture, recirculation

PROPELLER RPM

750 rpm

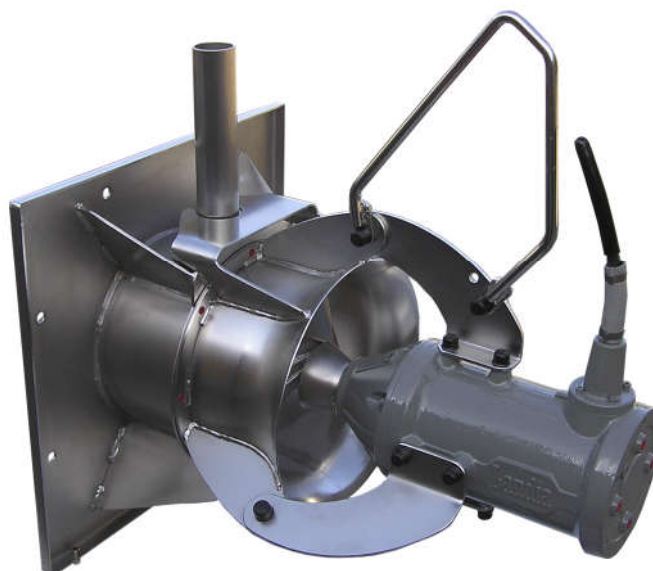

MATERIAL OF CONSTRUCTION

Motor housing and oil chamber	Cast iron EN-GJL-250
Propeller, volute insert and protection collar	Stainless steel W1.4301/AISI 304
Shaft	W1.6582/AISI4340
Bolts	A4
Sealing system	Mechanical shaft seals: silicon carbide/silicon carbide
Oil type	15W-40 Vario HDX (with moisture detection)

SERVICE AND MAINTENANCE

Recommended service interval/oil change	Maximum 2,500 operating hours/minimum once a year
Motor	Lifetime lubricated bearings
Oil chamber	Periodic oil change

SURFACE TREATMENT

2-component coating: RAL 7005 (Mouse Grey)

Mouse Grey

ELECTRICAL CABLE

H07RN-F/S07RN-F EUCAFLEX^{Plus} Cable.

Resistant to oil and UV radiation.

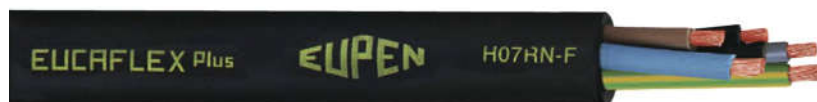

Number of conductors:

H07RN-F 7G1.5 mm² (Not used in United Kingdom)

H07RN-F 7G2.5 mm² (Only United Kingdom. Motor ≤ 5,5 kW)

As standard supplied with 7 m of cable (extra length available upon request).

MONITORING FUNCTIONS

Bimetal thermal sensors 120 °C

Moisture detection system (optional)

ELECTRICAL DATA

Motor type	3-phase AC motor
Nominal voltage	400 V
Minimum voltage allowed	360 V
Nominal frequency	50 Hz
Applicable for VFD operation	Yes
Ingress protection rating	IP 68
Insulation class	F
ATEX classification	II 2 G Ex db h IIB T4 Gb (Option, only available for specific models)

Model	Nominal power	Motor	Full load current (400 V)	Connection method	Start current (DOL)	cos phi	Efficiency
	[kW]	[rpm]	[A]	Y/Δ	[A]		[%]
AXD-I 300 1.5 kW-750 rpm	1.5	705	4.1	Y	18	0.70	75.4
AXD-I 300 2.2 kW-750 rpm	2.2	705	5.6	Y	25	0.75	75.6
AXD-I 300 3.0 kW-750 rpm	3.0	705	7.4	Δ	33	0.75	78.0
AXD-I 300 4.0 kW-750 rpm	4.0	710	9.3	Δ	37	0.78	79.6

For voltages others than 400 V/50 Hz please refer to the attached Appendix.

OVERALL DIMENSIONS

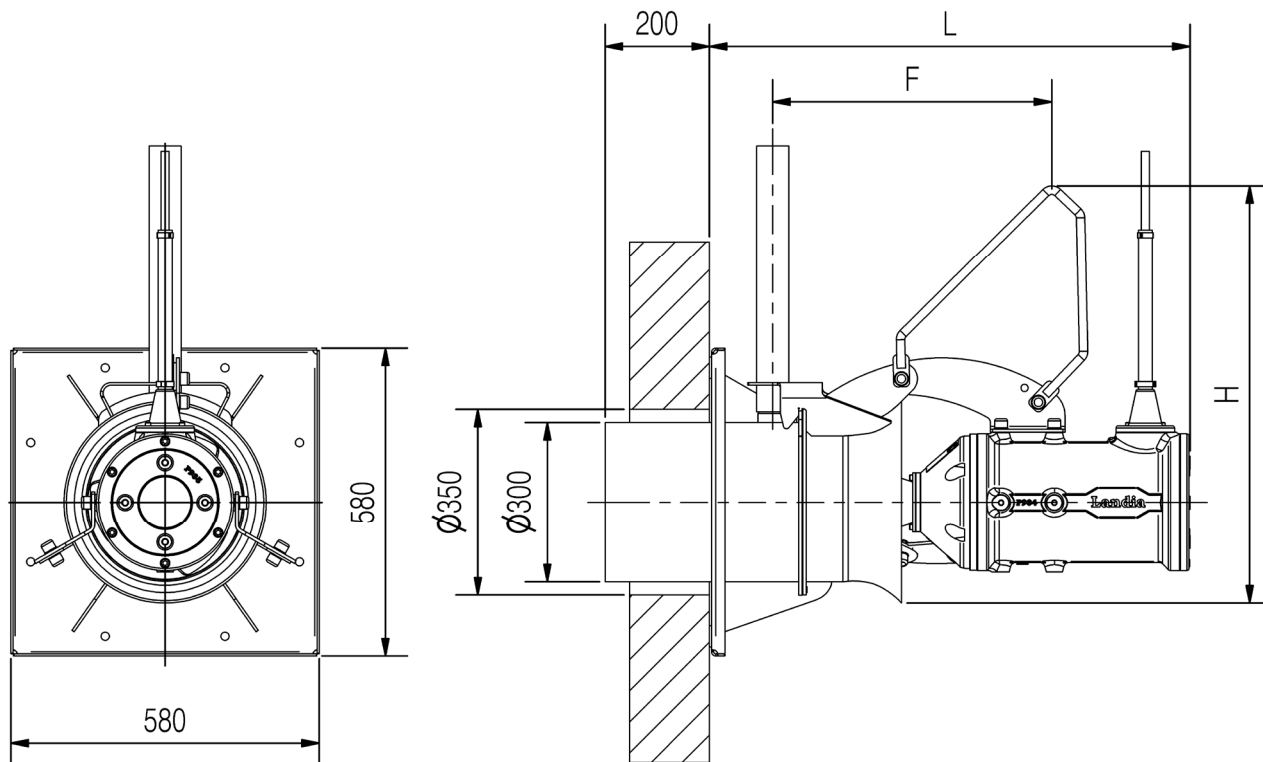

Model	F [mm]	H [mm]	L [mm]	Weight [kg]
AXD-I 300 1.5 kW-750 rpm	425	750	800	68
AXD-I 300 2.2 kW-750 rpm	470	730	845	76
AXD-I 300 3.0 kW-750 rpm	470	730	845	79
AXD-I 300 4.0 kW-750 rpm	530	800	915	113

We reserve the right to make technical changes.